

ML80 Fork Tool with Locking Cams

- 1. Lower tool over crate

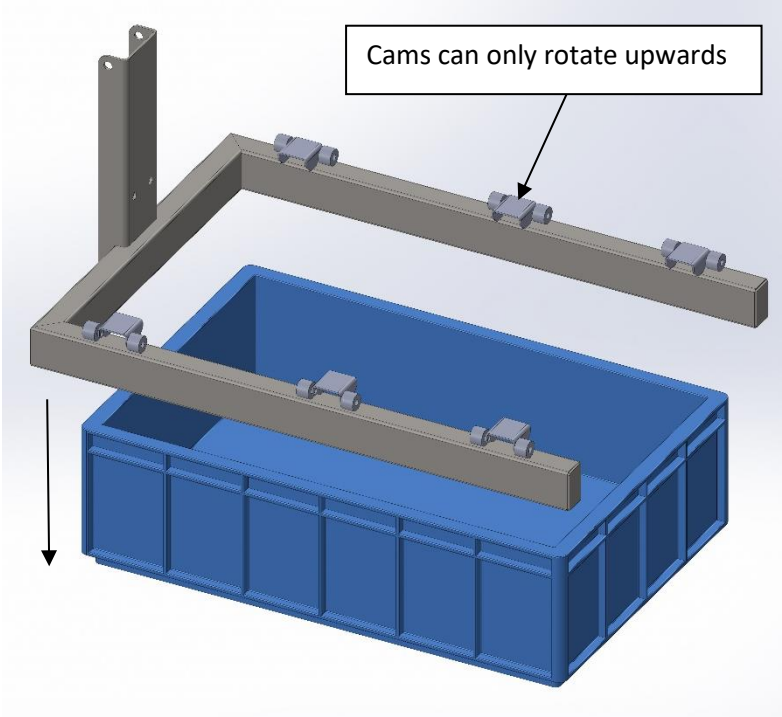

- 2. Locking cams contact crate, lower tool further

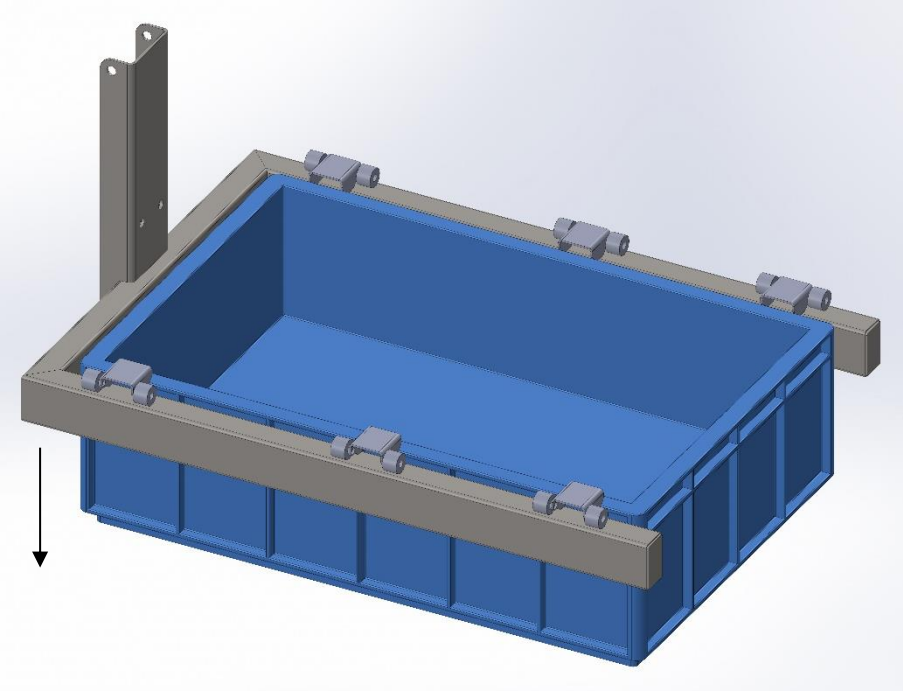

3. Locking cams rotate as tool is lowered

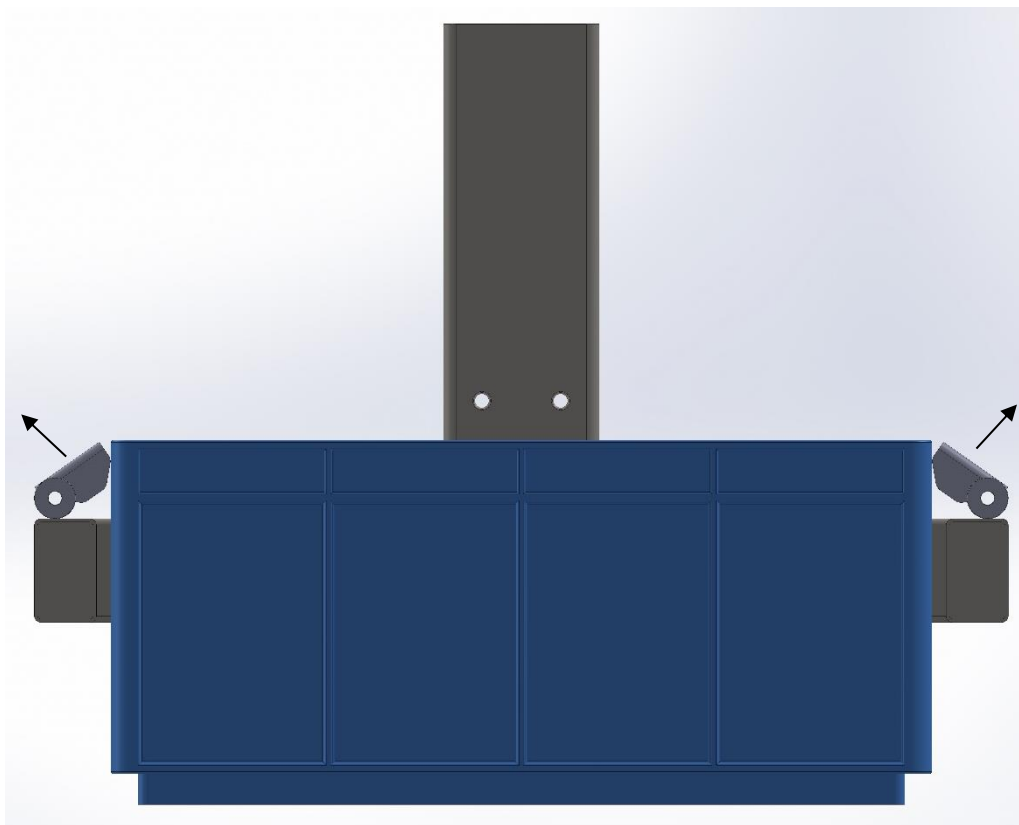
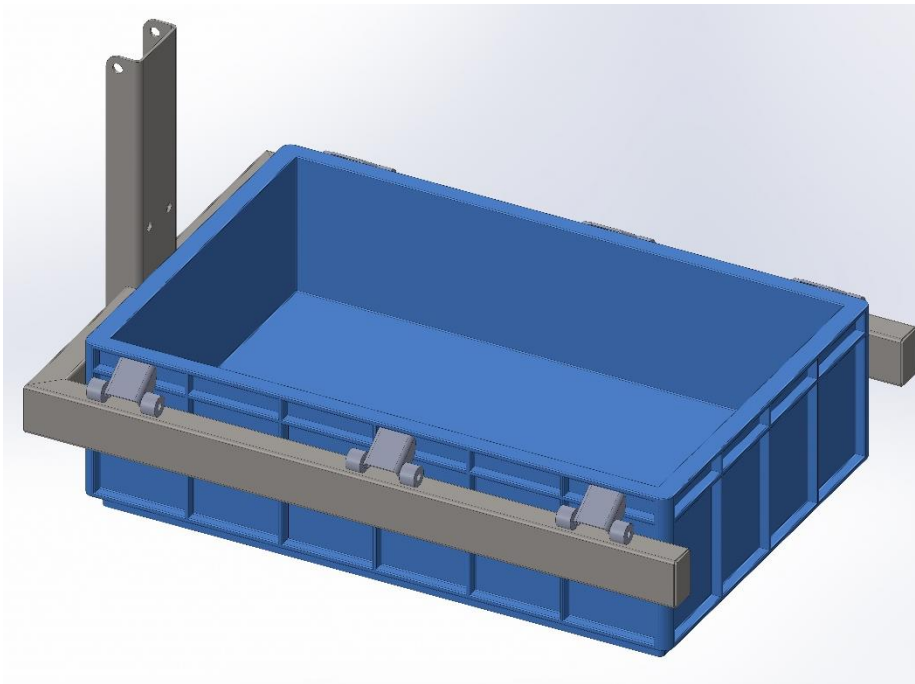

4. Cams drop into locked position, crate can now be lifted

